



# INSTALLATION, OPERATION AND MAINTENANCE INSTRUCTIONS

## REAR/OUTSIDE ACCESS, LE482 LED LIGHT FIXTURE FOR SPRAY PAINT BOOTH APPLICATIONS - CLEAN ROOMS

### WARNING!

1. TO PREVENT THE RISK OF ELECTRICAL SHOCK DEACTIVATE/DISCONNECT THE POWER SUPPLY BEFORE INSTALLING OR RELAMPING FIXTURE.
2. THE DRIVER IN THIS FIXTURE IS DESIGNED TO OPERATE ON GROUNDED NEUTRAL SYSTEMS ONLY.
3. THIS FIXTURE SHOULD BE INSTALLED BY QUALIFIED TECHNICIANS IN STRICT ACCORDANCE WITH THE NATIONAL ELECTRICAL CODE AND ANY LOCAL REQUIREMENTS.

### WARNINGS

CAUTION - Do Not Operate Paint Spray Booth When Fixture Frames Are Open. Keep Fixture Frames Tightly Closed While Paint Spray Booth is Operating

ATTENTION - Ne pas faire fonctionner la peinture cabine de projection Lorsque Cadres Fixture sont ouverts . Gardez Cadres Fixture bien fermés pendant la pulvérisation de peinture Booth fonctionne

"CAUTION - TO REDUCE THE RISK OF IGNITION OF HAZARDOUS ATMOSPHERES, DISCONNECT THE FIXTURE FROM THE SUPPLY CIRCUIT BEFORE OPENING. KEEP TIGHTLY CLOSED WHEN IN OPERATION."

ATTENTION - POUR RÉDUIRE LE RISQUE D' ALLUMAGE DES ENVIRONNEMENTS DANGEREUX , DECONNECTEZ L' APPAREIL DU CIRCUIT ELECTRIQUE AVANT D'OUVRIR . CONSERVER HERMETIQUEMENT FERME LORS DU FONCTIONNEMENT

### PAINT SPRAY BOOTH APPLICATIONS

The fixture should be sealed in such a way that only the face of the light fixture is exposed to the paint environment and the sides and rear are located in the Class I Division 2 environment.

**NOTE:** Light fixtures are only accessible from behind or outside of the booth. An interlock switch which has normally open contacts which open when fixture is accessed may be provided as an additional option. This switch is to be wired in such a way that it disables paint spray equipment when the front of the light is opened.

### OPERATIONAL DATA

Operate this fixture at its rated voltage. See fixture label for data. Do not install where the marked operating temperature exceeds the ignition temperature of the hazardous atmospheres.

## INSTALLATION

1. Mark opening on booth panel where fixture is to be located as shown per customer's applications.
2. Cut opening in booth panel using suitable tools.
3. Place light fixture into opening in booth panel, center, and mark locations of mounting holes. (4 ft. fixtures have 12 mounting holes.)
4. Remove fixture from booth panel and punch the 5/16" dia. mounting holes in panel.
5. Install light fixture into panel from inside of booth as shown. For horizontal mounting, mount with hinge on top side.

**NOTE:** Before installing fixture, make certain mounting gasket is installed on bottom surface of light mounting flange. Install mounting fasteners (not provided) and secure to booth panel. Customer is responsible for providing any panel reinforcements needed for mounting.

6. Caulk the flange perimeter with the same type of caulk as the spray booth.
7. Wire fixture through conduit hub according to schematic provided below.
8. Installation of light fixture onto panel is now complete.

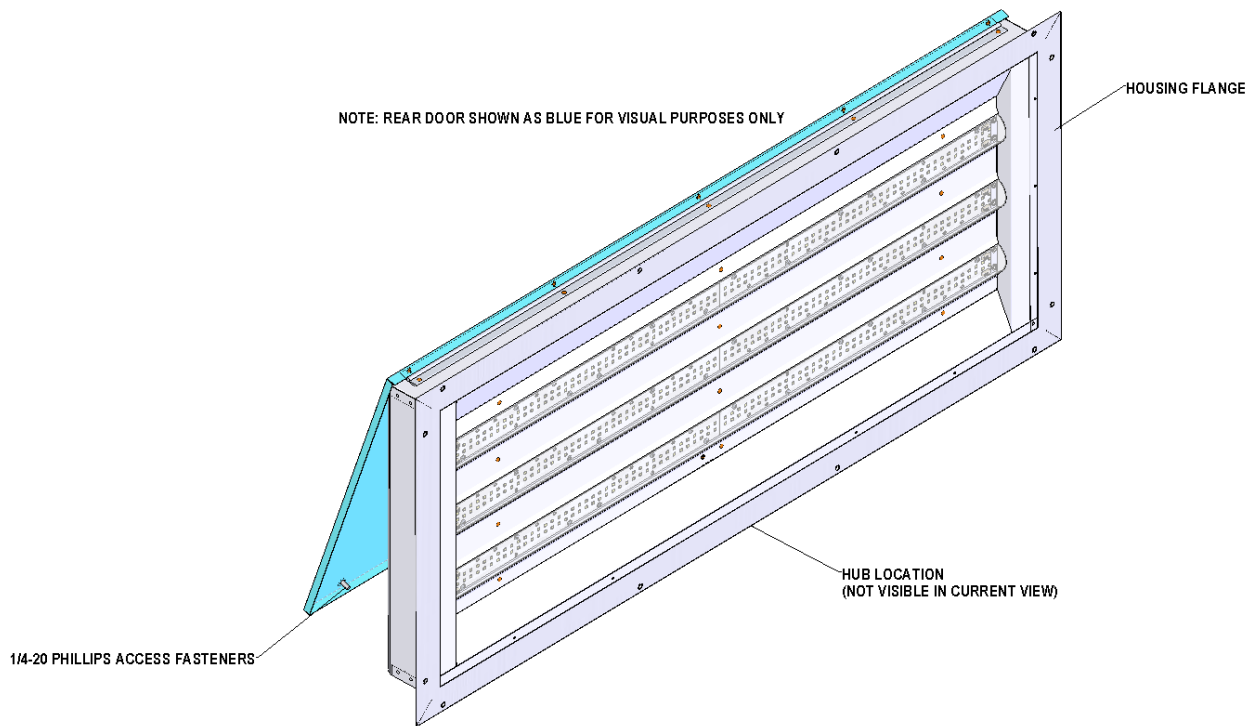

## Example of data label:

 Eau Claire, WI 54703 (715)839-9585	MODEL NO: LE482-218-V1-A-5	 63295
	PRODUCT CODE: 3C1400	
Conforms to ANSI/UL Std 844 & UL Std 1598 Certified to CAN/CSA Std C22.2 Nos. 250.0 & 137		
<b>LED RECESSED MOUNTED LUMINAIRE</b>		
ELECTRIC LIGHTING FIXTURE FOR PAINT SPRAY BOOTH APPLICATIONS.		
CLASS I, DIVISION 2, GROUPS A, B, C & D		
CLASS II, DIVISION 2, GROUPS F & G. SUITABLE FOR WET LOCATIONS.		
CLASS P BALLAST. SUITABLE FOR LOCATIONS HAVING DEPOSITS OF READILY COMBUSTIBLE PAINT RESIDUES.		
CONVIENT AUX EMPLACEMENTS MOUILLÉS		
120-277 VOLT	1.82-0.79 AMPS	218 WATTS
		50/60 HZ ONLY
	AMBIENT RATING -25°C TO 55°C	
May 31, 2017	MAX. TEMP. OPERATING CODE T3C (160 DEGREES C.)	P/N 16010

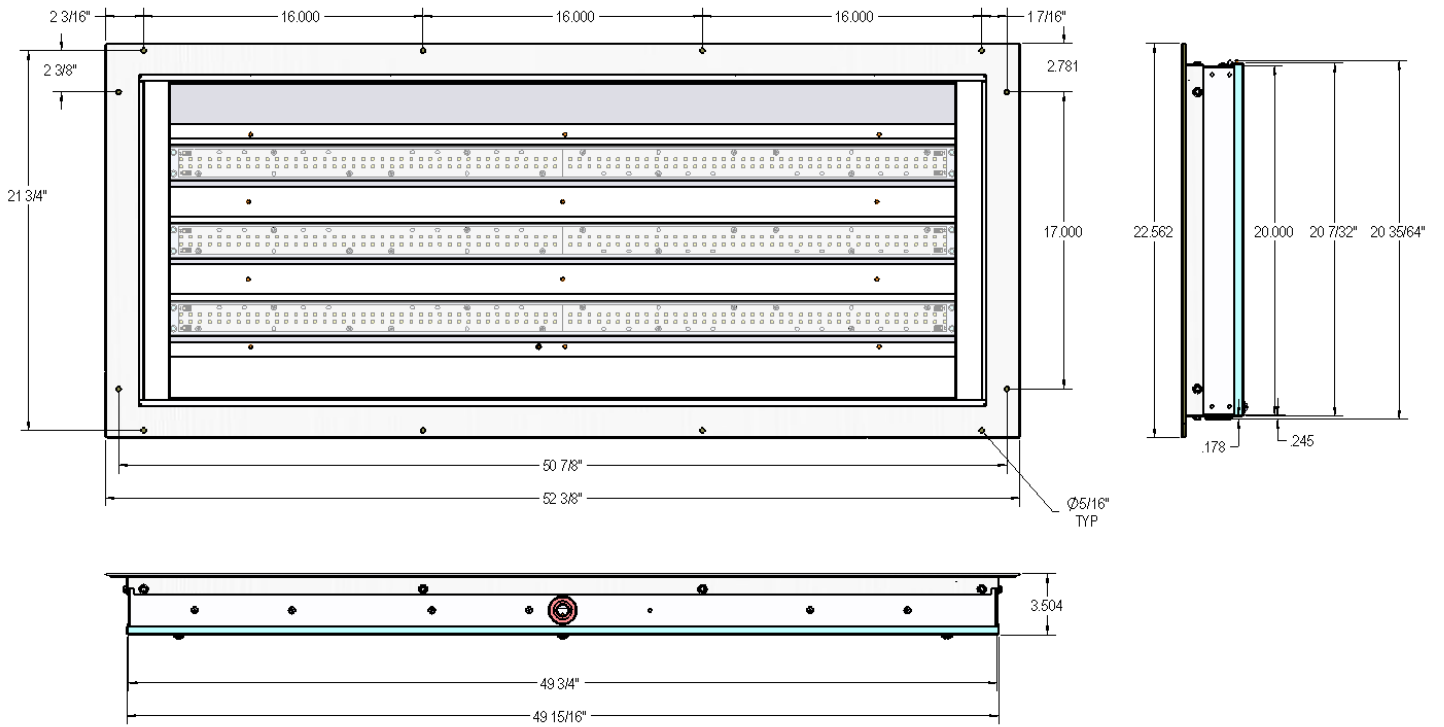

## CUT OUT DIMENSIONS

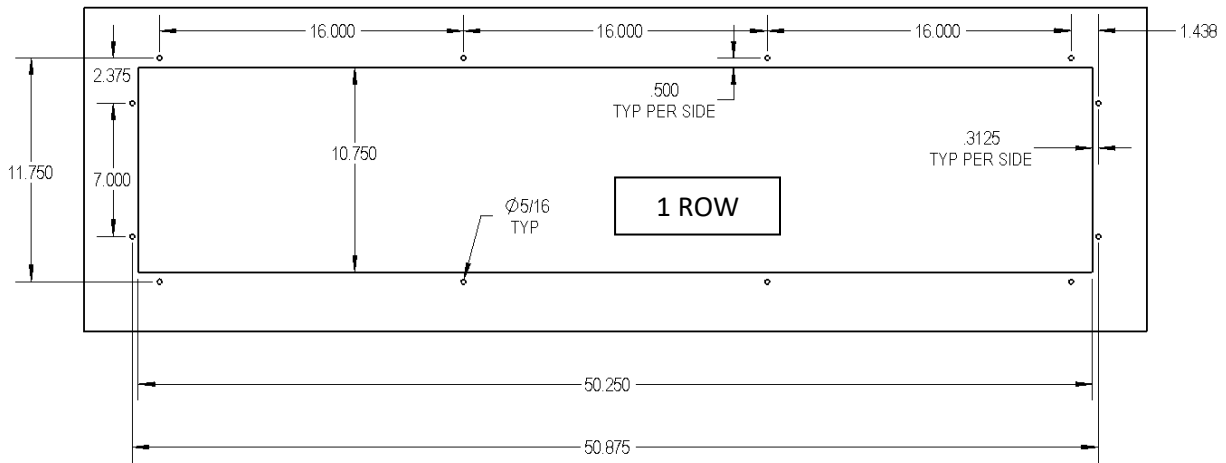

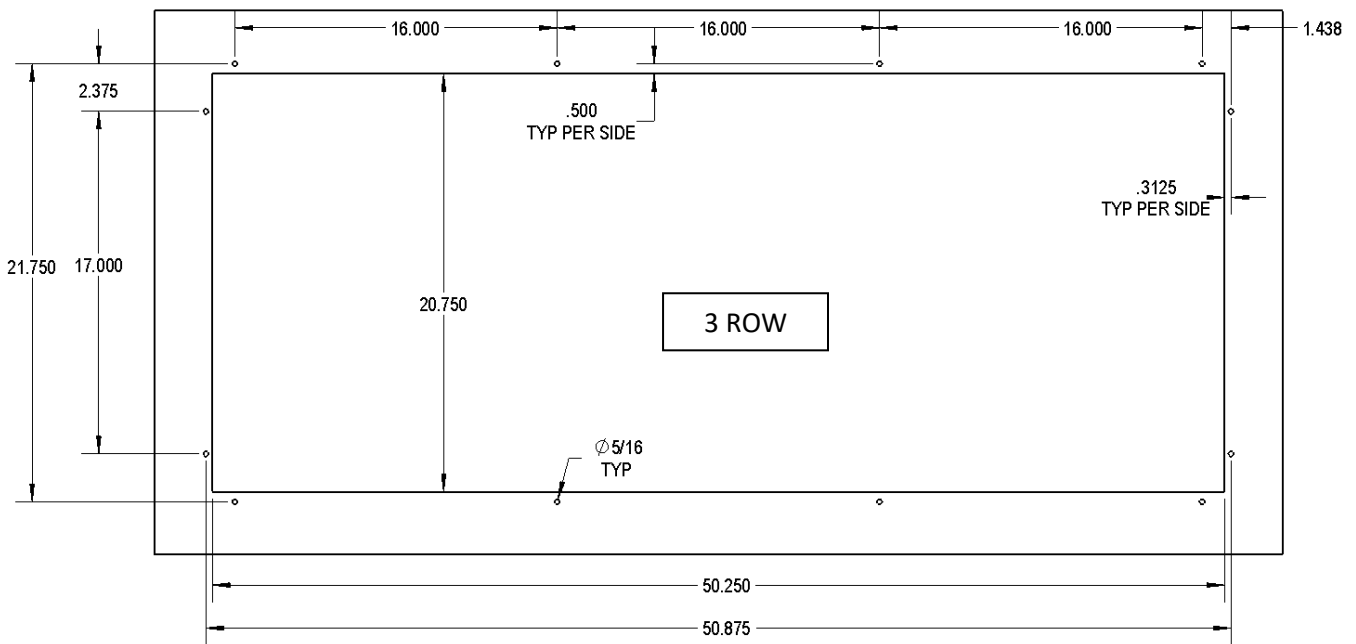
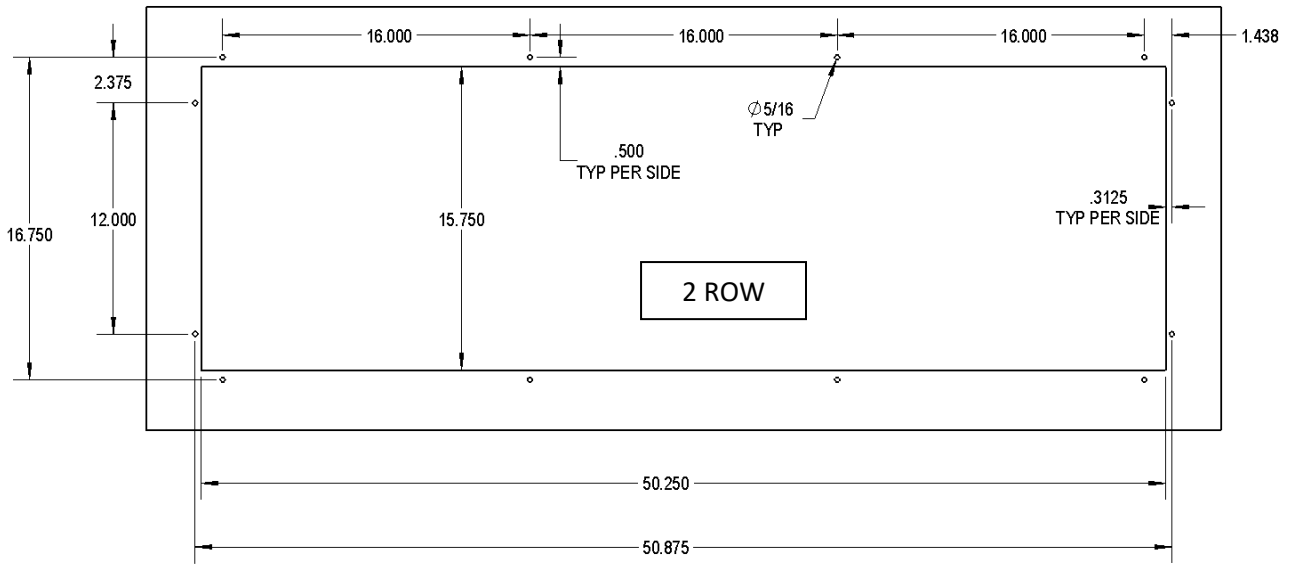

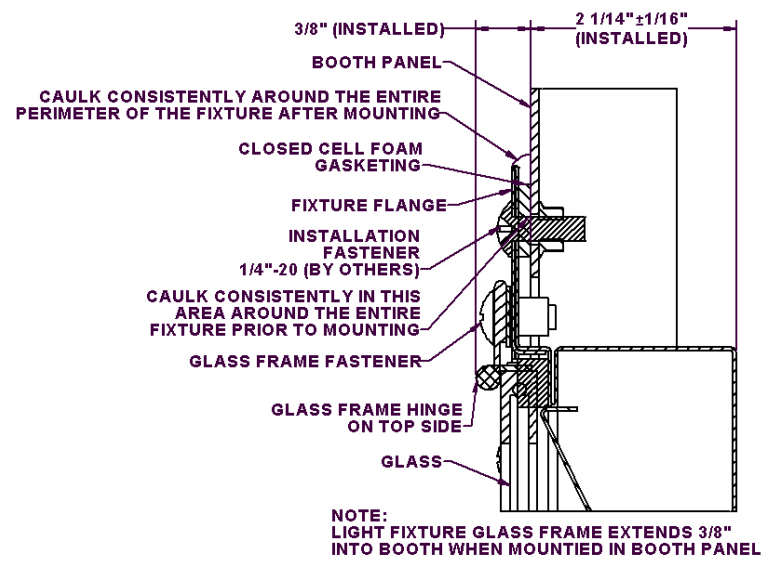
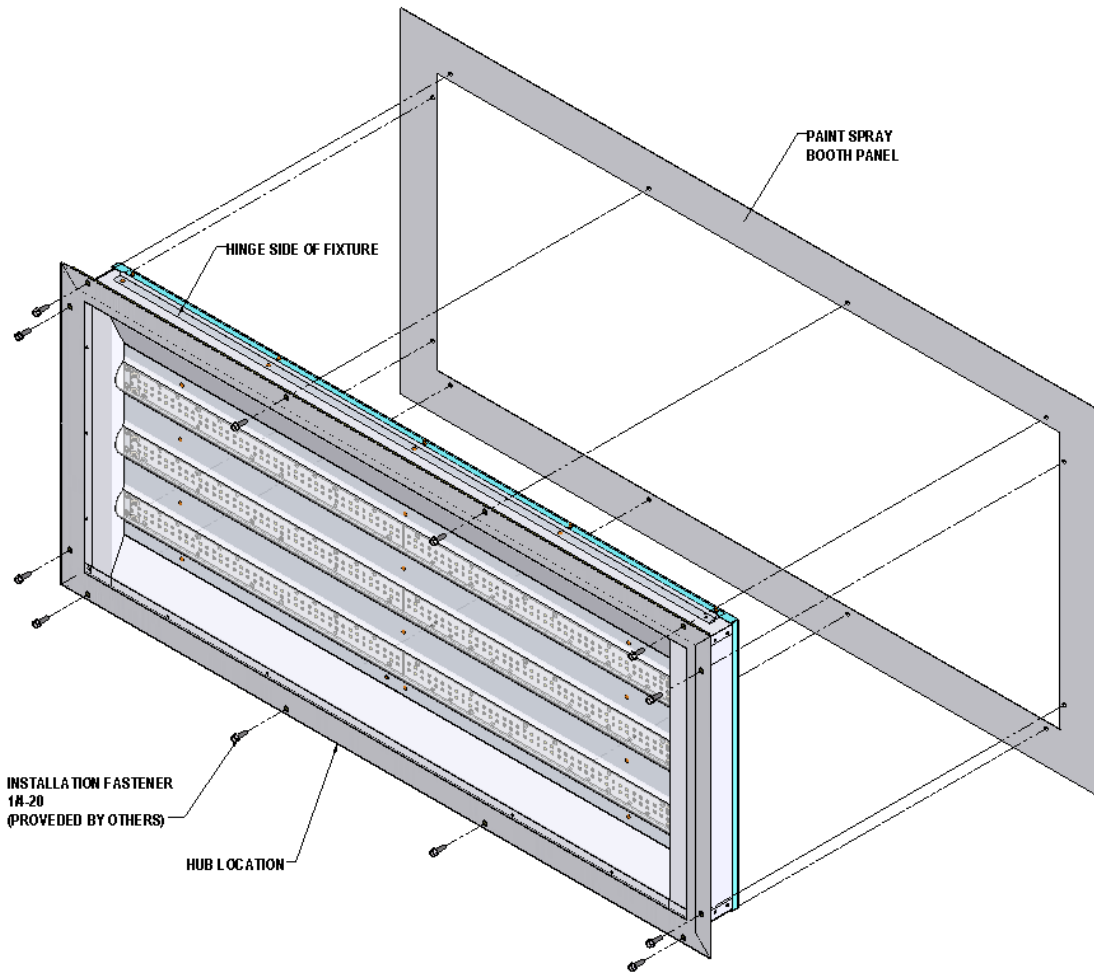

**MOUNTING DETAIL**

## WIRING SCHEMATIC - TYPICAL:

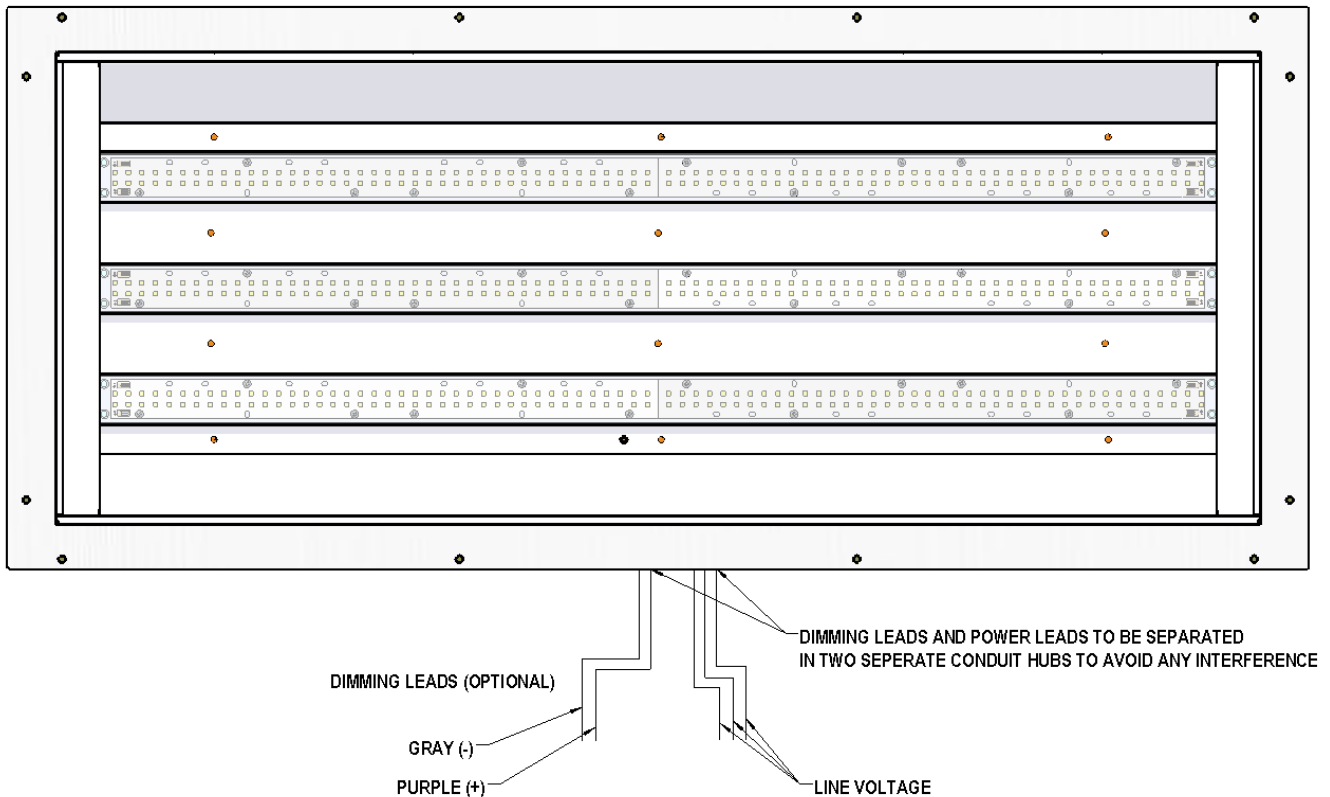

### NOTE:

Refer to diagram on ballast with specific wiring details.

## MAINTENANCE DATA

1. Although no routine maintenance is required to keep this fixture functional, it should be checked periodically to ensure that it is working properly and to look for any external damage.
2. For optimum performance, keep light transmission parts of fixture clean. Any commercial glass cleaner can be used to clean the glass.
3. In the event of glass breakage, it will be necessary to replace the damaged glass frame assembly, in order to maintain the integrity of the fixture.
4. To replace driver: Disconnect supply circuit. Remove qty 3 fasteners from rear door, opposite side from hinge. The door will swing open. Disconnect all yellow quick connections. Driver locations are shown in image below. To locate faulty driver, make sure the correct circuit between the driver and LED boards has been identified. This can be done by locating the two boards that are not working and following the leads back to the driver. Disconnect this driver and remove screws holding it in place. Replace with new driver, reconnect to the power and to the LED boards, reverse the steps to mount the driver and close the fixture.

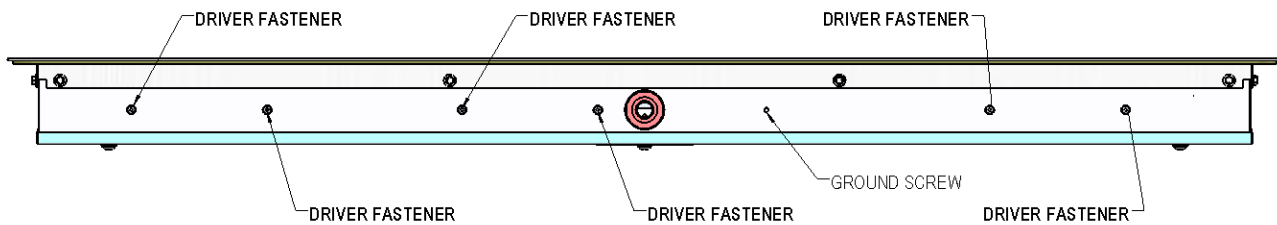
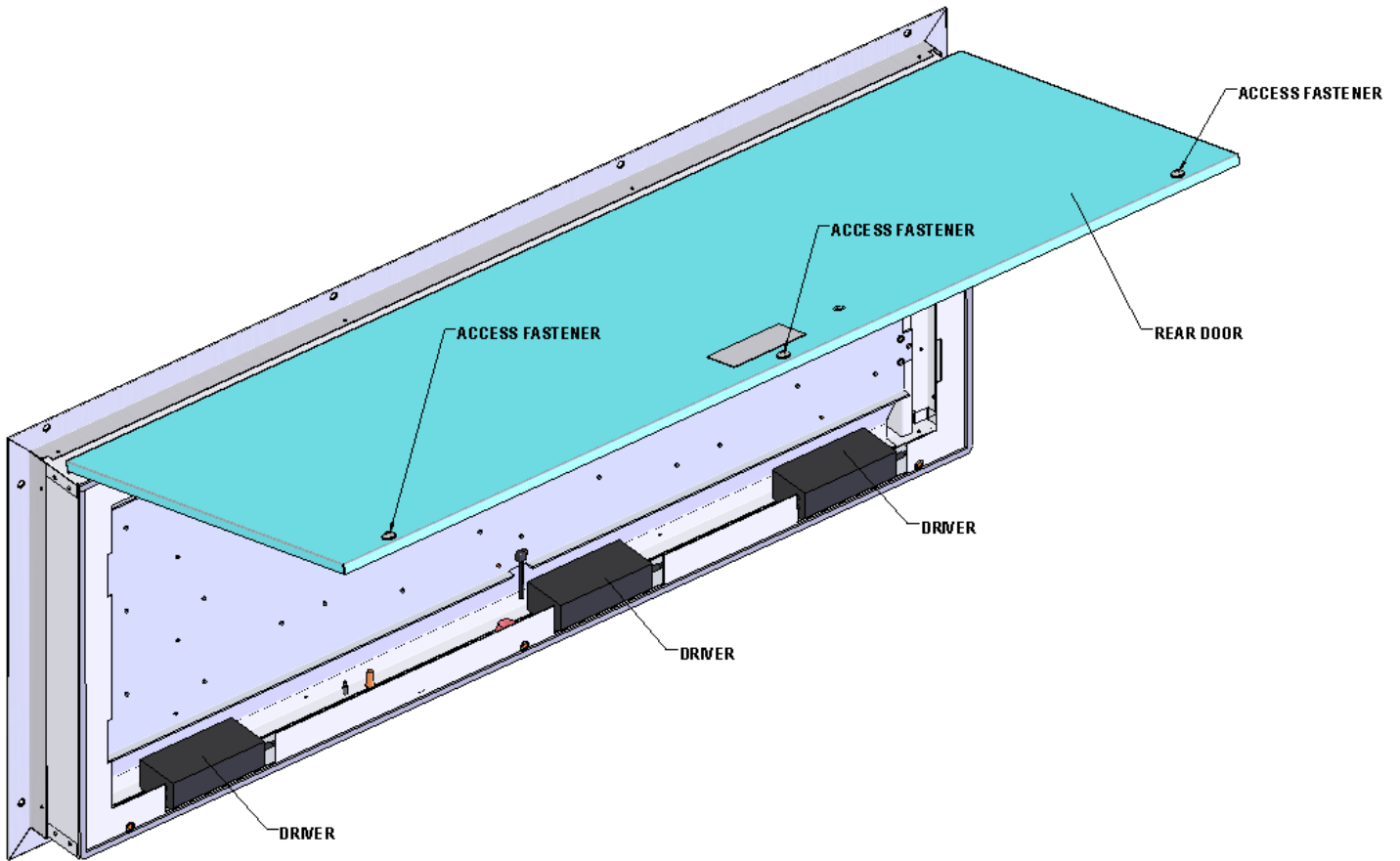

5. To replace board: Disconnect supply circuit. Remove qty 3 fasteners from rear door, opposite side from hinge. The door will swing open. Disconnect all yellow quick connections. Remove qty 4 fasteners from backside of heat sink tray. Remove heat sink tray and set on table or bench. Using a small flathead screwdriver gently depress the wire release on the board and carefully pull wire from connector on board, this must be done on both ends of the LED board. Remove board and dispose of in proper fashion. Connect new board, Boards are wired in a series, refer to schematic below. place optics in place and secure covers and reflectors. Close rear door and install fasteners in door to seal.

**\*\*Note - Basic Schematic, including dimming leads. Surge protection device and EM option not shown here.\*\***

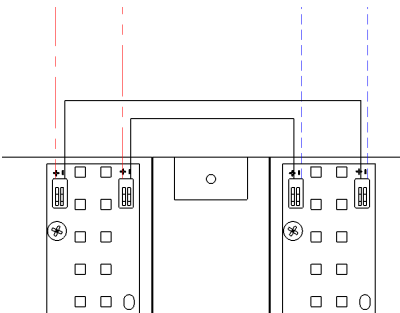
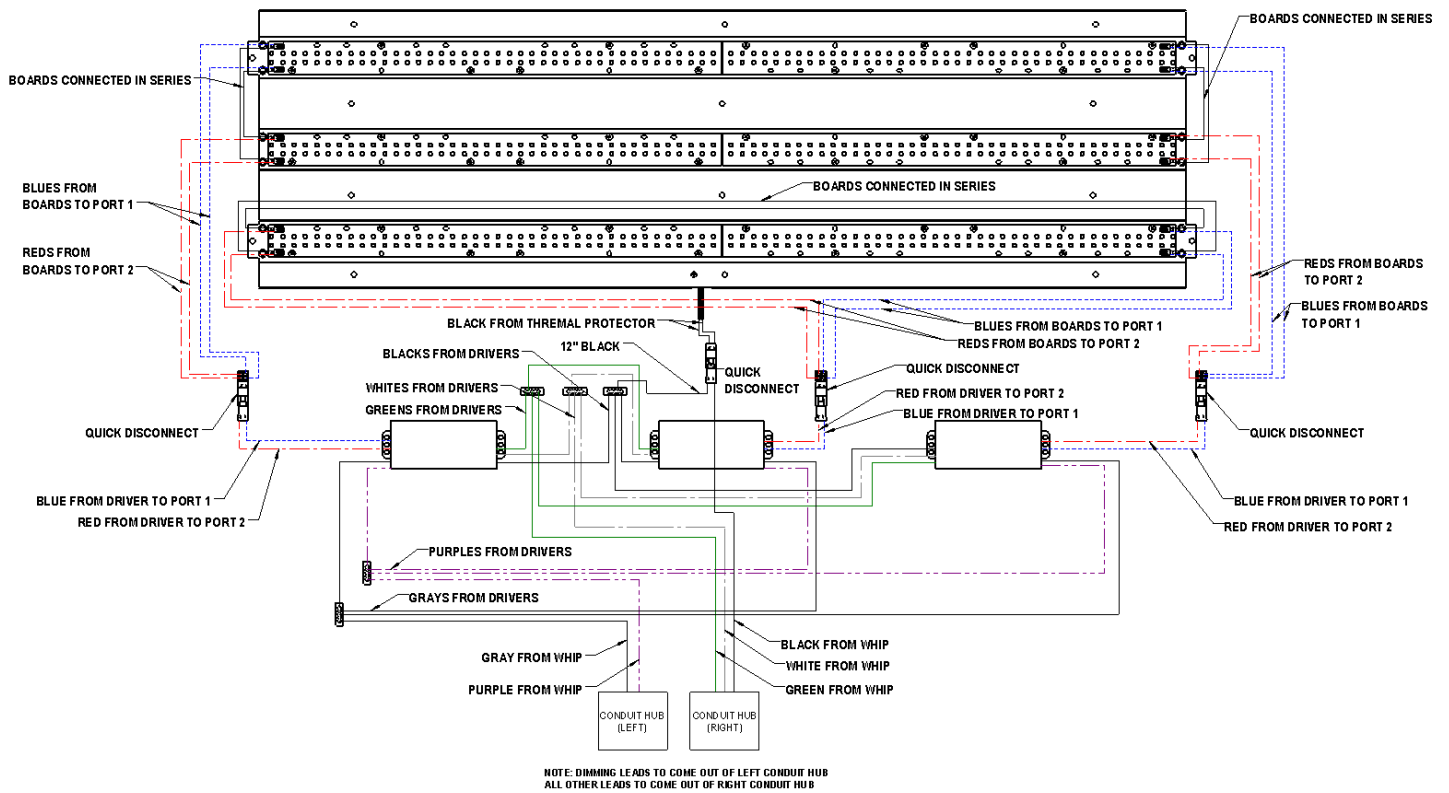

**NOTE:**  
BOARDS ARE CONNECTED IN SERIES